

Power take-offs and power take-off drive shafts

HSE information sheet

Agriculture Information Sheet No 40

Introduction

A tractor power take-off (PTO) and the power take-off drive shaft of a machine are very dangerous if used and not correctly guarded. Every year people are killed or seriously injured in accidents involving PTOs and PTO drive shafts.

Most of these accidents are preventable if the PTO and PTO drive shaft are fitted with guards of good design which are properly used and maintained.

Note: Broken, damaged or badly fitting guards can be just as dangerous as no guard at all.

This leaflet is aimed at all users of PTO-driven equipment.

Case study

A 26-year-old stockman was adapting the pump unit of a slurry tanker to provide vacuum drive to a milking unit. On stepping over the partially unguarded PTO shaft his left trouser leg became entangled in the revolving PTO, resulting in his leg being severed.

Guarding

- Protect the tractor PTO with a shield covering the top and both sides of the PTO so that it stops anyone making contact with it, either with parts of their body or their clothes. Make sure this shield is well constructed and capable of supporting a downward load of at least 120 kg. When the PTO is not in use, it may be covered by a fixed cap.
- Guard PTO drive shafts by enclosing them along their full length, from the tractor to the first bearing on the machine.
- Advice on guard dimensions and design specifications for agricultural PTO drive shaft guards is given in:
 - BS EN 12965:2003+A2:2009 *Tractors and machinery for agriculture and forestry. Power take-off (PTO) drive shafts and their guards. Safety*

– BS EN ISO 5674:2009 *Tractors and machinery for agriculture and forestry. Guards for power take-off (PTO) drive shafts. Strength and wear tests and acceptance criteria*

See HSE web pages 'Work equipment and machinery' for more information: www.hse.gov.uk/work-equipment-machinery/index.htm.

Choosing and fitting a guard

- Replacement PTO drive shaft guards sold individually must be CE marked and accompanied by a Declaration of Conformity unless sold as an identical spare part supplied by the manufacturer of the original machinery.

Important: Always refer to the manufacturer's fitting, operating and maintenance instructions.

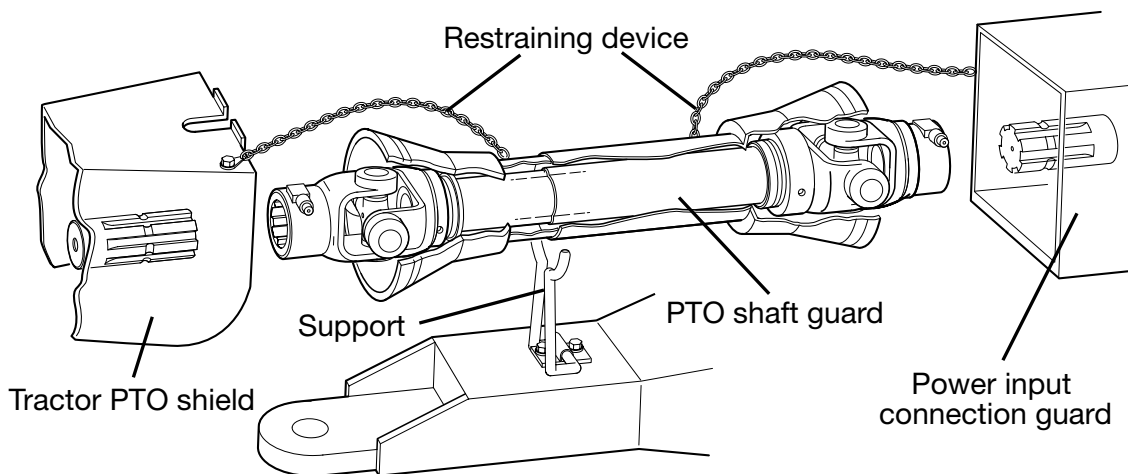

Figure 1 Cone and tube type guard

Case study

A 23-year-old employee was killed when he caught his waxed coat in the partly exposed revolving PTO drive shaft of a roller mill. He was dragged over the shaft and struck his head on one of the mill's supporting girders.

- Ensure the spring-loaded plunger of the quick release yoke is adequately lubricated. Again, a lithium-based grease is best.
- Check that wide-angle joints are not exposed at tractor/implement turning angles.
- Both the tractor PTO shield and the power input connection guard must overlap the PTO drive shaft guard by at least 50 mm.

Points to consider for the guards shown in Figure 2

Points to consider for the guards shown in Figure 1

- Ensure the closed and extended length of the guard and the drive shaft are right for the tractor and machine. The guard tubes should be slightly shorter than the appropriate drive shaft telescopic halves by not more than 25 mm, so that they will not separate at its longest length or 'bottom' at its shortest.
- Ensure the guard's bearings are secure in the correct position on the drive shaft grooves, and a restraining device, eg a rope or chain, is in place to prevent the guard rotating with the shaft.
- Attach restraining devices at suitable points. At the machine end they should be attached near the power input connection guard, and at the tractor end they should be coupled to a hole in the PTO master shield. Make sure there are no restrictions to allow for vertical and side movement.
- Clean the sliding inner and outer surfaces of the guard daily and lubricate the guard bearings weekly (or more frequently if the manufacturer recommends it) with a lithium-based grease. Similarly, grease the sliding drive shaft halves and the grease nipples at universal joints in accordance with the manufacturer's operating and maintenance instructions (normally before starting work and after every eight hours of use).

- Check that end plates are fitted, eg bolted to the tractor and implement.
- Ensure the guard is held correctly to both the tractor and implement end plates.
- Check for wear, holes, deformation of the guard etc and replace if necessary.

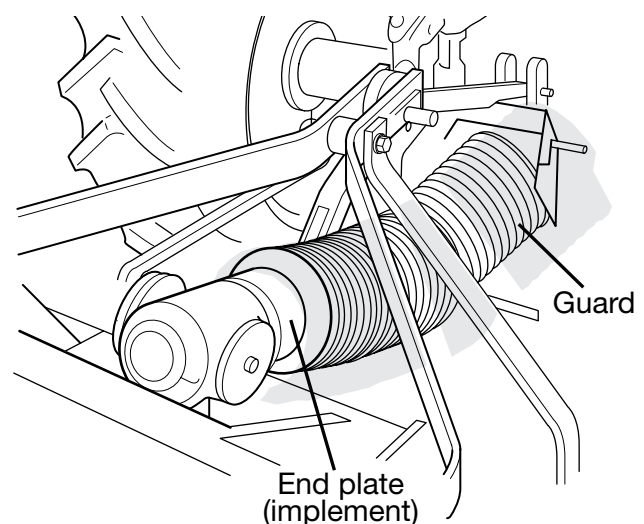

Figure 2 Bellows type guard

For all guards

- Check all guards regularly, eg daily when in use, for wear and damage. Damaged guards must be replaced before use.
- Where it is necessary to have some form of protection in the PTO drive line, torque limiters, free wheels or clutches should be located at the power input connection (machine end) of the PTO drive shaft.
- The restraining devices used to prevent the rotation of the drive shaft guard should not be used as a means of supporting the PTO shaft/guard when the machine is uncoupled.

How to avoid damage to the PTO drive shaft and guards

- When the machine is not in use, support the shaft and guard on the cradle provided. If there is no cradle, support the shaft and guard by other means to give equivalent protection against damage.
- Do not rest PTO shafts and guards on drawbars and do not drop them on the ground.
- Make sure drawbar pins of trailed machines cannot foul and damage the shaft guard. The recommended height of pins above the drawbar is 20 mm. Allow enough clearance between the guard and any parts of the tractor and machine to prevent the guard being fouled. This is particularly important when working on undulating land.
- Note that the restraining devices fitted to guards may not be capable of supporting longer or heavier shafts when the machine is uncoupled.

Safe use

- Ensure no one is in danger before engaging the PTO drive, eg sound the tractor horn to warn bystanders.
- Don't turn too sharply as this could cause the lower links or tractor tyre to foul the PTO drive shaft. Lower link arms may need adjusting to prevent this. Always disengage the PTO drive when making sharp turns.
- Do not wear scarves, loose or damaged clothing, eg loose anorak cords, which could be caught in moving parts. It is advisable when operating any machinery to tie back long hair, and wear overalls or close-fitting clothing.

Never

- Try to clear blockages from a PTO-driven machine while it is running.

Always

- Disengage the power drive first.

Remember

- Carry out **safe stop**:
 - hand brake on;
 - make sure controls are in neutral;
 - engine off;
 - remove the key;
 - wait for all movement to cease before attempting to clear any blockage;
 - where possible, use a tool to clear the blockage.

Dual-speed PTOs

- Shafts for the two speeds are different: six splines for the 540 rpm and 21 splines for the 1000 rpm. In both cases the speed should be achieved at not less than 80% of the engine-rated speed.
- Any adaptor allowing a six splined shaft to drive 1000 rpm machines is potentially dangerous and is not recommended. Adaptors create the further problem of extending the length of the shaft so that the standard guard no longer offers the necessary protection.
- **Do not** drive the machine too fast. If a machine is used in excess of its design speed it will come under too much stress and it could disintegrate. This can be caused by using the wrong shaft speed or too high an engine speed when using an adaptor.
- Make sure you use the right shaft and engine speed.

Information, instruction and training

Everyone who works with PTO-driven machinery needs to know how to work safely. Operators require clear instructions, information and adequate training on:

- the risks they may face when using PTOs and PTO drive shafts;
- measures in place to control the risks;
- how to set up and use PTO drive shafts safely.

For more specific advice, see HSE leaflet *Health and safety training: A brief guide* INDG345(rev1) www.hse.gov.uk/pubns/indg345.htm.

Further information

For information about health and safety, or to report inconsistencies or inaccuracies in this guidance, visit www.hse.gov.uk/. You can view HSE guidance online and order priced publications from the website. HSE priced publications are also available from bookshops.

This guidance is issued by the Health and Safety Executive. Following the guidance is not compulsory, unless specifically stated, and you are free to take other action. But if you do follow the guidance you will normally be doing enough to comply with the law. Health and safety inspectors seek to secure compliance with the law and may refer to this guidance.

This leaflet is available at:
www.hse.gov.uk/pubns/ais40.htm.

© *Crown copyright* If you wish to reuse this information visit www.hse.gov.uk/copyright.htm for details. First published 01/13.